

RESEARCH ON DETERIORATION FOR RAKANJI STONE ARCH BRIDGE, HONYABAKEI, OITA, JAPAN

T. Aoki^{*}, T. Komiyama[†], S. Miyata[†], M. Miura[†] and Y. Igarashi[†]

^{*} Graduate School of Design and Architecture, Nagoya City University
Kitachikusa 2-1-10, Chikusa, 464-0083 Nagoya, Japan

Email: aoki@sda.nagoya-cu.ac.jp - Web page: <http://www.sda.nagoya-cu.ac.jp/aoki>

[†] Constec Engineering Co., Ltd., Itachibori 6-7-51, Osaka, Japan
e-mail: t-komiyama@constec.co.jp, web page: <http://www.constec.co.jp/>

Key words: Stone arch bridge, Deterioration, Non-destructive test, Destructive test, Diagnostic inspection

Abstract. *Stone and/or brick have been usually used as construction materials in Europe from thousands years ago. There are a great number of masonry structures in Europe. Also in Japan, especially in Kyushu, there are over a thousand stone arch bridges built before 1925. The arch technology perfected in ancient Rome was introduced to Nagasaki by Portuguese in the early 17th century. The oldest remaining stone arch bridge in Japan, “Nagasaki Spectacles Bridge (Meganebashi in Japanese)” was constructed in 1634. The name is derived from the appearance of the bridge and its reflection in the riverⁱ. The construction of Rakanji stone arch bridge over the Yamakuni River, Honyabakei, Oita, started in 1917. During the construction, the stone arch bridge had gone through collapse twice before its completion in 1920ⁱⁱ. It has three spans of about 26 meters and total length of the bridge is about 89.3 meters. The rise of the arches is about 5.1 meters and the radical thickness of the stone arches is about 0.93 meter. Rise span ratio is about 0.19, in other words, arches are very shallow. The width of the bridge is about 4.5 meters. In order to make proposals for the structural conservation and restoration, a series of non-destructive and destructive tests for diagnostic inspection of deterioration on Rakanji stone arch bridge was carried out. The following points will be discussed in the paper. 1) Estimation of the thickness of the wall panels by means of Electromagnetic Radar, 2) Clarification of the inner structure of the stone arch bridge by means of Electromagnetic Radar, Fiberscope and Core Drilling Tests, 3) Estimation of the compressive strength and Young’s modulus of the stone and the mortar by means of Small Core Tests, and 4) Diagnostic inspection of deterioration on Piers by means of Submarine Camera.*

1 INTRODUCTION

The technology of Stone Arch Bridge in Japan was introduced from Korea and China as well as other cultures. Kintai Bridge, one of very rare timber arch bridges was constructed in Iwakuni, Hiroshima in 1673. However, the technology of stone arch bridge was introduced to Okinawa in the middle 15th century, about 200 years before the construction of Kintai Bridge. After 200 years, Meganebashi, one of the most famous stone arch bridges in Japan was constructed over the Nakajima River in Nagasaki by Nyojyo, a Chinese priest ⁱⁱⁱ.

This is the beginning of the history of the stone arch bridge in Japan and after that a lot of stone arch bridges were constructed all over Kyushu. In the Japanese style of architecture consisting mainly of timber structure, it is a peculiar fact that only Kyushu has a lot of stone arch bridges and it symbolizes the Kyushu's unique culture in Japan, affected by European culture.

Therefore, stone arch bridges are considered to be very important historic structures in order to study the technologies, fashions, styles and cultures existed after the middle 17th century in Japan.

However, in order to maintain the beauty and structural stability of the bridge, the necessity of diagnostic inspection to grasp present condition and structural analysis have been pointed out ^{iv,v,vi}.

Various tests and measurements were carried out to evaluate the deterioration of the bridge, and theoretical and experimental dynamic analysis to assess structural stability of the bridge ^{vii}.

The following reports the results of on site research, and the result of structural analysis will be reported in the next paper.



Figure 1: Rakanji Stone Arch Bridge

2 OVERVIEW OF RAKANJI STONE ARCH BRIDGE

The Photograph and drawing of Rakanji stone arch bridge are shown in Figure 1 and Figure 2 respectively. The construction of Rakanji stone arch bridge over the Yamakuni River, Honyabakei, Oita, started in 1917 by Shinnosuke MATSUDA and Mankichi IWABUCHI, famous engineers in the construction field in the period. During the construction, the bridge had gone through collapse twice before its completion in 1920. It has three spans of about 26 meters and total length of the bridge is about 89.3 meters. The rise of the arches is about 5.1 meters and the radical thickness of the stone arches is about 0.93 meter. Rise span ratio is about 0.19, in other words, arches are very shallow. The width of the bridge is about 4.5 meters. The bridge has been designated for the cultural property by Oita prefecture because of its grandness, elegance and historic value ⁱⁱ.

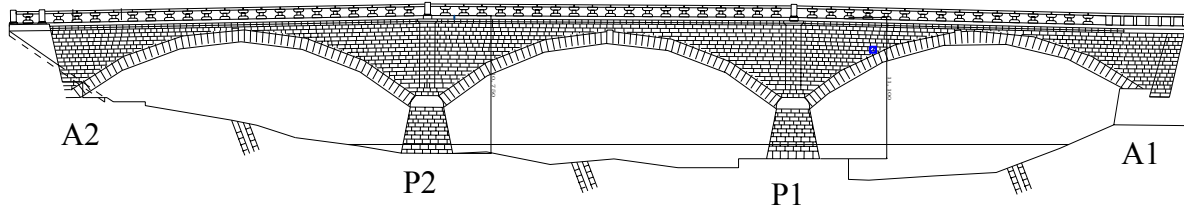

Figure 2: Elevation of North Side of Rakanji Stone Arch Bridge

3 RESULTS OF INVESTIGATION

3.1 Visual inspection

The stratum about Rakanji stone arch bridge is called Yabakeiso consisting of volcanic detritus. Yabakeiso was generated in the Pleistocene period and the thickness is about 300 meters.

The ground around Rakanji stone arch bridge consists of tuff breccia. The stone consists of volcanic ash and andesite or welded tuff. The stone was very hard and no geological disorder was observed. However, a lot of cracks were observed on the surface of asphalt pavement around Pier A1 and near the access road of the bridge. Since some gaps were found between the concrete slab and the subbase of clay by the observation using fiberscope, the cause of the cracks was estimated to be the weariness induced by the generation of the gaps. The cause of the generation of the gaps was estimated to be the settlement of subbase caused by traffic loads.

As the results of visual inspection and hammering test, the arch stones and spandrel were confirmed to be healthy on the whole. However, vertical cracks with the width of 20~30mm were found on the spandrel near Pier 1 and Pier 2 (Figure 3). Also, there existed some cracks in the crossing direction of the bridge on the asphalt pavement on those piers (Figure 4). The cause of those cracks was estimated to be the creep induced by dead loads of arches working as tensile forces to those areas.

Fortunately, the bad influences of those cracks on the structural integrity of the bridge were not considered to be serious, as those cracks have not reached the arch stones. However, if not repaired, the cracks will extend gradually and influence the stability and function of the bridge.

Mortar joint was partially damaged by vegetation and should be repaired. However, other parts without crack and vegetation seemed to be healthy and did not deteriorate heavily.

A lot of delaminations, separations and cracks were appearing on the handrail. However, no deformation and looseness that can cause fatal accidents such as fall of stones or collapse of the handrail was found. Physical deterioration of the stones of the handrail seemed to be not serious.

Remarkable cracks with the width of approximately 10mm were discovered on the asphalt pavement near Pier 1 and Pier 2 where tensile forces act. The cause of the cracks was estimated to be the creep induced by the dead load of the arches as well as that of cracks on

the spandrel. And cracks extending in the parallel direction to the rut of road were observed on the asphalt pavement of the bridge near Pier 2 between Pier 2 and Abutment 2. Since gaps were discovered between the concrete slabs and the subbase clay layers generated by the settlement of the subbase clay layers, the cause of those cracks were estimated to be the vibration of the concrete slabs isolated from the subbase clay layer.

The influence of those cracks on the durability of the bridge was not considered to be serious, however, in order to keep the traffic safety, a large-scale repair work of subbase, slabs and asphalt pavement is required.



Figure 3: Cracks on Spandrel



Figure 4: Cracks on Asphalt Pavement

3.2 Results of material tests

In order to evaluate the conditions of materials of each depth separately, small cores of 350mm length obtained from the spandrel were cut into three pieces at 0mm~50mm (surface part), 50mm~250mm (middle part) and 250~350mm (deep part) from the surface (Figure 5) and compressive strength and Young's modulus were measured. Total numbers of small cores of mortar, spandrel and handrail stones are four, four and two, respectively. Also, two cores were penetrated to the rear side of the spandrel in order to measure the width of the stones.

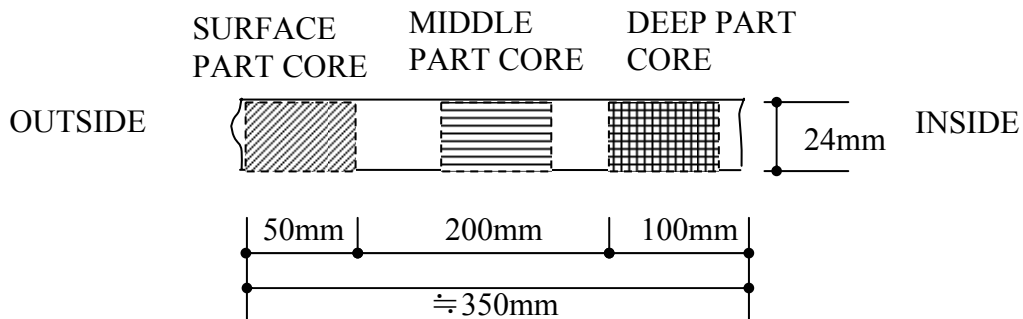

Figure 5: Small Core Tested

3.2.1 Material tests of stones

In the material tests, average specific gravity of air-dried stones of the spandrel was 1.83, average compressive strength was 28.5 N/mm^2 and average Young's modulus was 17224.2 N/mm^2 . The average compressive strength of the stones of surface part, middle part and deep part were 27.8 N/mm^2 , 28.2 N/mm^2 , and 30.3 N/mm^2 respectively (Figure 6). The average Young's modulus of the stones of surface part, middle part and deep part were 17502.4 N/mm^2 , 17284.4 N/mm^2 , and 16720.7 N/mm^2 respectively (Figure 6). In spite of the tendency that compressive strength of the stones becomes higher as the depth from the surface becomes large, Young's modulus showed the opposite tendency. So, as the results of material tests, it could not be said that the deterioration of the stones of surface part were serious compared to those of deep part.

On the other hand, the average specific gravity of air-dried stones of the handrail was 1.78, average compressive strength was 26.5 N/mm^2 and average Young's modulus was 12307.6 N/mm^2 and the results show that stones used for the handrail are light and weak compared to those of the bridge body.

3.2.2 Material tests of joint mortar

The results of material tests of mortar cores obtained on the spandrel are shown in Figure 7. In the visual inspection of mortar cores, it was confirmed that the mortar had been stuffed densely into the gap of stones, and almost healthy in the deeper part up to the surface. However, since many mortar cores were broken in the surface part when sampled from the bridge and compressive strength and Young's modulus were relatively lower than those of the mortars obtained from deeper parts, the degradation of the mortar was estimated to be progressing from the surface.

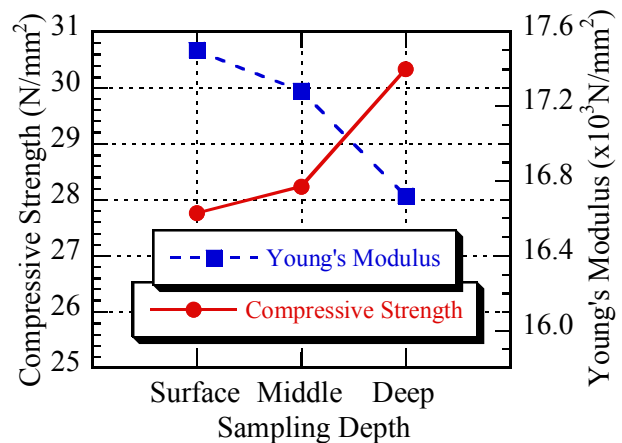

Figure 6: Physical Properties of Stone Cores

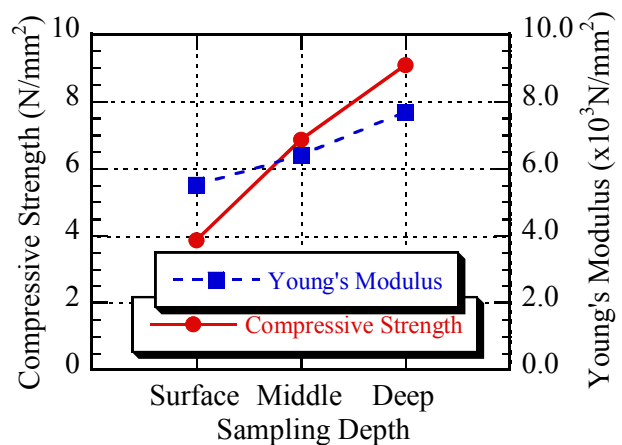
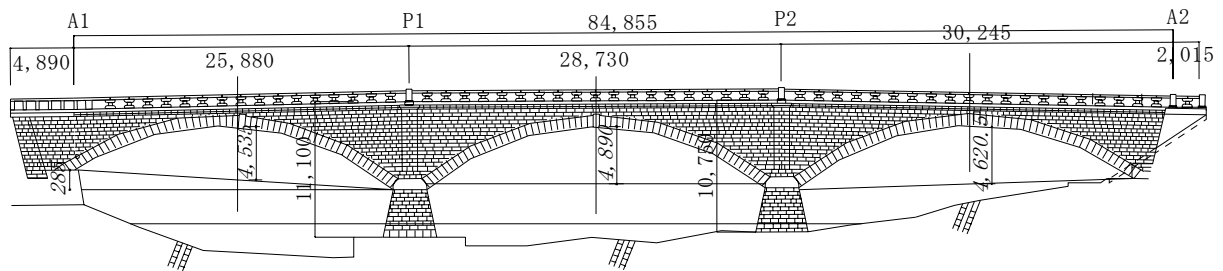

Figure 7: Physical Properties of Mortar Cores

3.3 Results of measure

The results of measure of the bridge and thickness of stones are shown in Figure 8. The thicknesses of the stones of the spandrel were estimated from the results of Rader scanning (Figure 9), small core sampling, and pattern of the mortar joint. Since the original plan of the bridge did not remain, reviewing of the quantity of deformation was impossible. However, these results can be a valuable material for the health monitoring from now on.



(a) Elevation of North Side

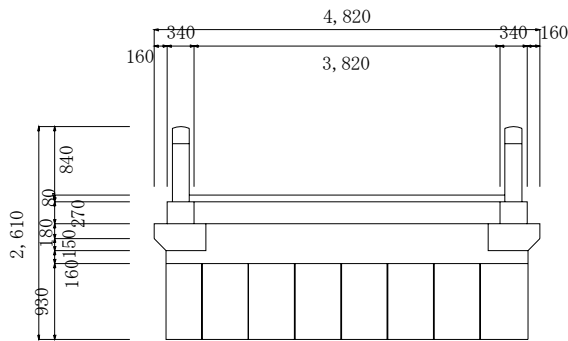

(b) Section in the middle of Arch

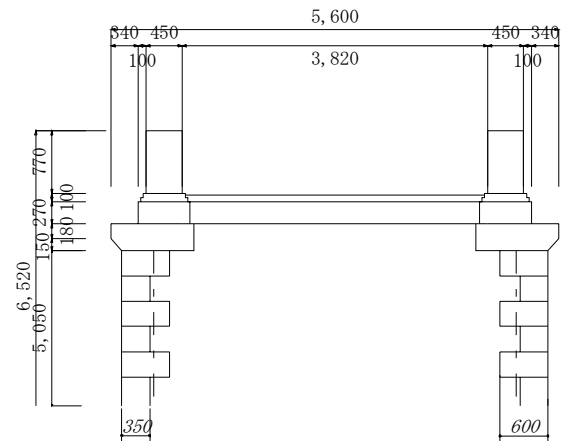

(c) Section of Pier

Figure 8: Results of Measure (unit: mm)

3.4 Inspection on inside cavity

The scanned image of the spandrel by the electromagnetic radar is shown in Figure 9. The thickness of spandrel is estimated to be 45cm by the Figure. However, the measurements obtained from two places are 350mm and 600mm, and it is supposed that the scanned image showed the average thickness of those values. The white, crescent-shaped reflected image seen on the many parts in the Figure indicates the existence of cavities inside.

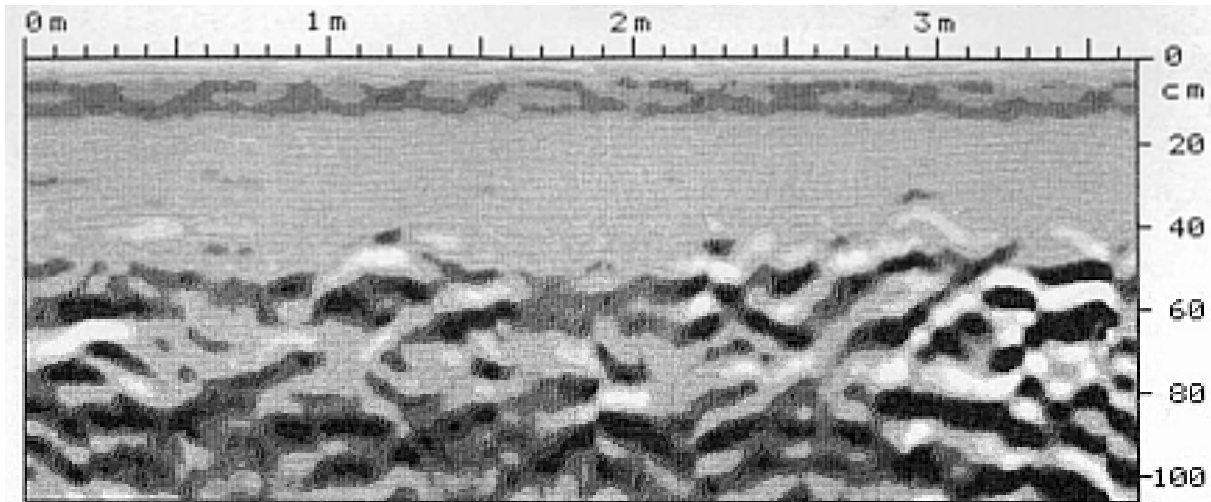

Figure 9: Scanned Image of Spandrel by Electromagnetic Radar

The state of the stuffing stones inspected by the fiberscope is shown in Figure 10. The stuffing stones contain a lot of cavities and in such condition that relatively big-sized stones support each other by point contact, which is unlike gravel. The state of the inside bridge presumed by the result of inspections with the radar, fiberscope and all coring is shown in Figure 11.



Figure 10: State of Stuffing Stones Observed by Fiberscope

The thickness of the asphalt, concrete slab, and subbase clay layer were about 80mm, 120mm and 500mm, respectively, and there was no abnormality to make special mention of.

Under the subbase clay layer is the gravel layer, where each stone piles up by point contact with a lot of cavities in the gaps. On the other hand, the layer deeper than 5.0m is solid with a few cavities, consisting of welded tuff and tuffaceous andesite with the filling of mortar containing gravel. The result of the inspections leads to the presumption as follows; in the construction of the pier, the stones were piled up in the outer frame with the gravel and mortar filling, and cobblestones of andesite and welded tuff were put inside to form primitive concrete. Above that is the layer consisting of stone debris, river stones, earth and sand, which was considered as “weight” to stabilize the arch by dead load. From the structural viewpoint, if the weight of the stuffing stones is sufficient, the inside cavities seems no problem because the stuffing stones only play a role of “weight” for arch action of the arch stone. However, as independency of the stuffing stones is low, inside cavities would cause lateral pressure on the spandrel if left as they are. And if the bridge should collapse when the stuffing stones inside the bridge supporting each

other by point contact become off balance, it would lower the bearing force of the upper subbase clay layer and concrete slab, and could cause troubles for road traffic. As the result of all coring, it was confirmed that cavities might be developing near the consolidation concrete of foundation of the pier, and the same measures as the stuffing stones' would be necessary.

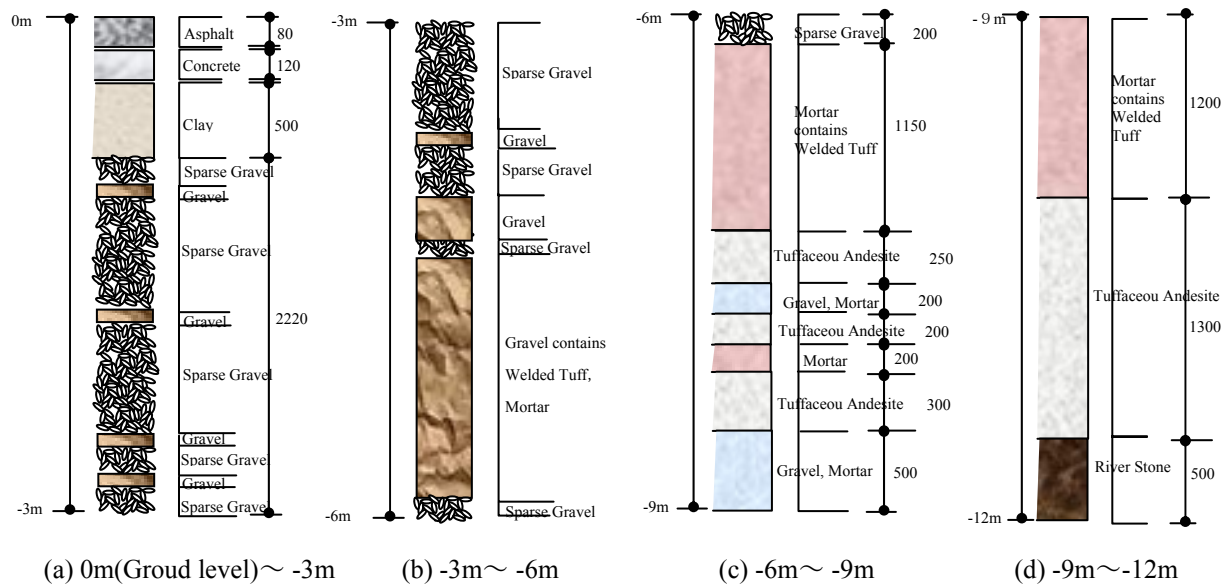

Figure 11: Estimated Inner Structure of the Bridge

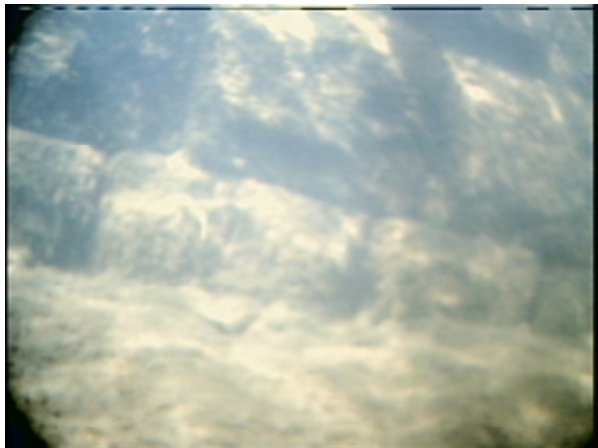

Figure 12: Sound part of Pier in underwater



Figure 13: Gap between Pier and River Bed

3.5 Inspection on underwater foundation

As the result of the inspections by the submarine video, the pier below the surface of water was sound, and no damage was found (Figure 12). However, some parts of consolidation concrete (the side face on A1 of P1 pier) could not be inspected by the camera, and gaps caused by scouring are likely to be developing between the side and the river-bed (Figure 13).

However, the gaps are slight, and it is possible that they have been existing there since the construction. And the risk that the gaps might have a serious effect on the stability of the bridge is low, although the safety would improve if the consolidation concrete was additionally reinforced.

4 CONCLUSIONS

Knowledges acquired as results of the investigation are as follows.

- The foundation and surrounding ground are quite sound and no remarkable disorder is discovered.
- The chemical deterioration of the stones is slight except surface, however, the deterioration of joint mortar is serious, and restoring is required.
- Vertical cracks with the width of 20~30mm are found on the spandrel near Pier 1 and Pier 2. The cause of those cracks is estimated to be dead loads of arches working for a long time as tensile forces to those areas and reinforcement is required.
- The stuffing stones contain a lot of cavities. Stones with the size of 20~30cm support each other by point contact. Judgment is difficult whether this condition has been made in the construction or generated by long-time spillage of stuffing sand. However, in order to prevent concrete slabs from damaging by the falling of stuffing stones, grouting or other measures are required.
- No remarkable damage is observed on underwater parts of the piers. However, a gap existing under consolidation concrete is discovered and additional consolidation is required.

REFERENCES

-
- [i] Nagasaki web site, citation http://www1.city.nagasaki.nagasaki.jp/ajisai/1/1_03e.html .
 - [ii] Honyabakei web site, <http://www.honyabakei.com/> (in Japanese).
 - [iii] H. Matsuda, “Culture of Bridge and Technology”, web site <http://www.lw.st.nagasaki-u.ac.jp/~matsuda/home-page/bridge.html> (in Japanese).
 - [iv] T. Aoki, “Structural Characteristics of Isahaya Arch Bridge –1– Structural Role of the Sludge Foundation”, *Proceedings of Annual Convention of A.I.J. (Kyushu Branch)*, 321–324 (1992), (in Japanese).
 - [v] T. Aoki and A. Miyamura, “Evaluation of Isahaya Stone Arch Bridge from the Viewpoints of Material, Profile and Performance Design”, *Invitation to Design and Architecture II*, Chunichi Newspaper Inc., 227–246 (1998), (in Japanese).
 - [vi] T. Aoki, A. Miyamura and S. Di Pasquale, “Failure Analysis of Masonry Arches”, *Proceedings of 4th International Conference on Computational Structures Technology (Civil-comp press)*, Edinburgh, August 18–20, 213–219 (1998).
 - [vii] Constec Engineering Co., Ltd., *Report on Rakanji Stone Arch Bridge*, Constec Engineering Co., Ltd., 1–93 (2003), (in Japanese).