

The influence of spandrel wall construction on arch bridge behaviour

W.J. Harvey

Bill Harvey Associates Ltd, Exeter, UK

E.A.W. Maunder

University of Exeter, School of Engineering, Computer Science, Mathematics, Exeter, UK

A.C.A. Ramsay

Ramsay Maunder Associates, Lincoln, UK

ABSTRACT: It has recently become clear that, at least in Britain, masonry arches for rail bridges commonly include internal spandrel walls. Typically a wall is placed under each rail and is stabilised with soil fill. This paper presents the results of an investigation of the behaviour of a typical wall of a spandrel arch bridge with the particular aim of defining a structural system in a simple but realistic way for the transfer of concentrated loads applied to the top of the spandrel wall. The bridge is modelled with two complementary finite element models, one based on conforming and one based on equilibrating elements, and as a simple one dimensional curved tapered beam having an inverted T section. The latter models focus on the determination of the interaction between a spandrel wall and the arch ring via the arch extrados.

1 INTRODUCTION

Ruddock (1974) in his historical review of hollow spandrels dates the use of internal longitudinal spandrel walls in Britain to Smeaton's repair of Dumbarton bridge in 1769. Photographs of the war damaged Mostar bridge show that Ottoman engineers were using them as early as 1535. There is no doubt, however, that throughout the construction period of the turnpike roads and the railways, the technique was known and, increasingly, practiced.

A bridge with longitudinal spandrel walls instead of soil fill must use very different load paths. There can be no transverse distribution in the fill, but the walls represent a significant element of the primary structure for carrying live loads. This study was prompted by the realisation that a very high proportion of railway bridges were being assessed using analytical tools which were manifestly incapable of representing real behaviour.

Hollow spandrels were introduced as a form of weight saving. On the largest bridges they were probably very necessary structurally as the outer walls would become unstable or unreasonably thick with increasing depth. Indeed, in larger bridges there is probably less masonry required for a hollow spandrel bridge than one with fill. Once the technique had been introduced, the structural advantages became apparent and with the increased loads of railway bridges, and intermediate solution was found where the spandrel walls were constructed under the rails and fill between them provided the necessary stability. Examples of this form are known in stone bridges in Scotland and brick ones in SE England (here the walls are only 1 brick thick). At another extreme, bridges on the Dundee to Friocheim railway have independent arch rings and spandrel walls and were obviously originally decked with timber. Typical construction for the larger bridges is shown in Figure 1 of the Lugar viaduct. At the lowest level, the arch is filled

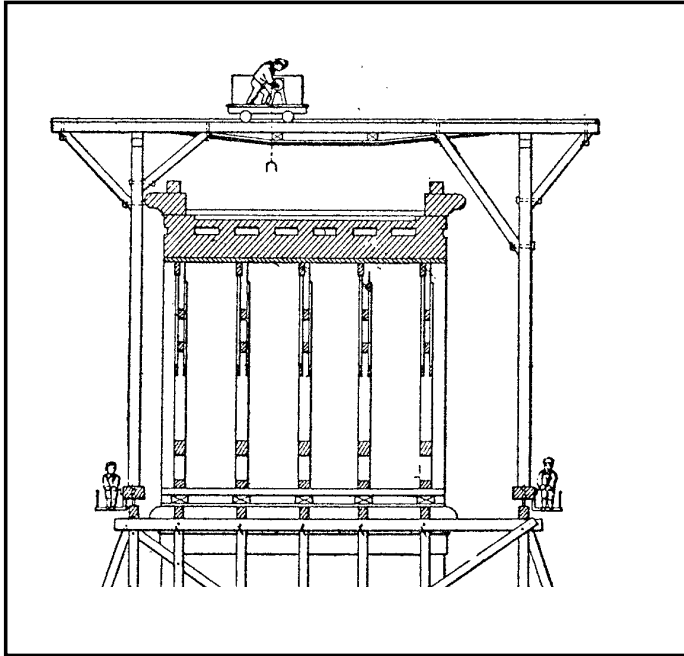

Figure 1: Internal spandrel walls at Lugar Bridge

with solid masonry, but this gives way to a series of walls, often with cross walls to enhance stability. A deck is provided using stone slabs, where these are available, or jack arches. Smeaton's technique of tying the jack arches with wrought iron bars bedded in the concrete above them does not seem to have survived into the railway era.

This paper aims to show that internal spandrel walls contribute considerably to arch behaviour. Assessing such bridges as if they were filled with soil is unlikely to over-estimate capacity, but it will lead to a lack of consideration of likely mechanisms of deterioration, which are vitally important.

Section 2 describes the geometry of a typical spandrel arch which is then analysed in Section 3 by finite element models based on linear elastic behaviour. A curved beam model is presented in Section 4 as a simplified model for investigating shear interactions between the spandrel wall and the arch ring. Section 5 summarises the current investigation in the context of bridge assessment.

2 A TYPICAL SPANDREL ARCH FOR STUDY

Figure 2 illustrates a typical spandrel arch that will be used to study this type of masonry structure. The following assumptions are made for the purposes of the current study: the arch ring is 0.78m thick and has an effective width 1.5m, the spandrel wall is 0.6m in width with a minimum depth of 0.2m at the crown, the arch ring has a constant radius of curvature of 12.5m, and the abutments are rigid and provide support to the arch ring alone.

Loading consists of a concentrated vertical load of 100kN applied to the top of the spandrel wall at a quarter point of the span, and the self weight of the masonry with a density of 2000 kg/m³. The masonry of the arch ring has a Young's modulus of 10 kN/mm² and a Poisson's ratio of 0.2. The spandrel wall is considered with alternative elastic constants to simulate a range of "soft" or "hard" dispersions of a concentrated load through the spandrel wall onto the extrados of the arch ring. Thus for the hard case the elastic constants are the same as the arch ring, but for the soft case it is assumed that the Young's modulus is only 0.01 kN/mm² and Poisson's ratio is zero.

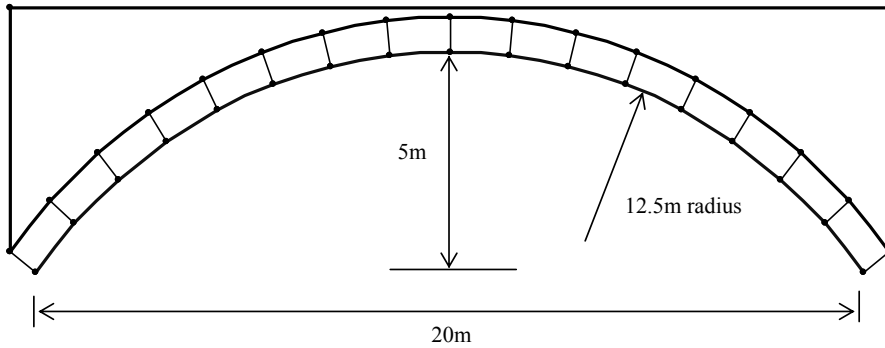

Figure 2: Spandrel arch for study

3 USE OF FINITE ELEMENT MODELS

Detailed analyses are carried out using finite element models based on linear elastic behaviour. Whilst such behaviour might be questionable even for normal loads, and the constitutive relations for masonry are unlikely to be known with any precision, the analyses do help to define feasible structural systems in the form of equilibrating internal force paths.

Two forms of finite element model are used to complement each other. The first uses conforming elements which are the more conventional, and hence are most commonly used in practice. However, their primary roles are to provide information about deflections whilst equilibrium is only satisfied in a weak sense. The second uses hybrid equilibrium elements with the primary roles of providing complete descriptions of equilibrium whether in the form of interactive tractions between elements or stress distributions within elements. In the present context of seeking to define feasible structural systems, the equilibrium model thus provides an important tool. Furthermore the use of both types of model permit assessments to be made as to the accuracy of their solutions in modelling the behaviour of structures based on linear elastic assumptions.

3.1 Conforming models

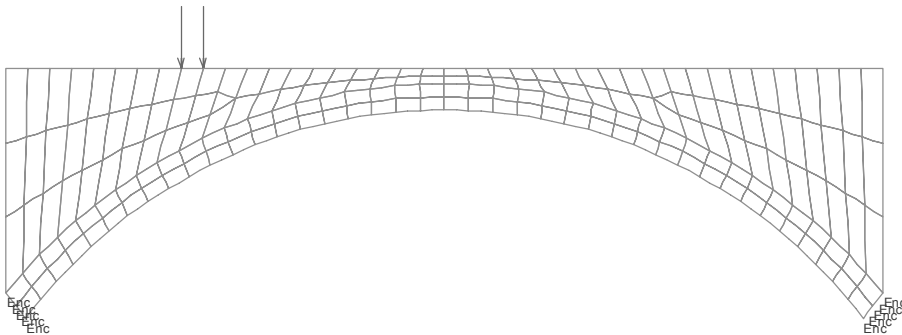

Figure 3: mesh for a conforming finite element model.

Figure 3 shows the mesh used for the conforming models. The elements are 8 or 6 noded quadrilaterals or triangles used as for plane stress. The concentrated load is applied as an edge load to one element at the position shown.

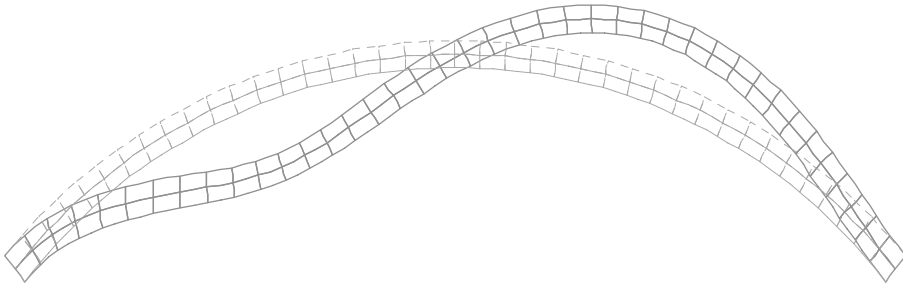

Figure 4: Deformed view of arch ring with soft spandrel wall.

Figure 4 shows the deflected form of the arch ring for the case of the soft spandrel wall and only the concentrated load acts. An overall view of the load dispersion onto the arch is indicated by the plot of principal stresses shown in Figure 5. Dispersion in this case appears to be essentially confined to be within a wedge with sides at about 30° to 45° to the vertical as delineated in the Figure. Load transfer then takes place around the arch ring with significant bending moments and consequent tensile stresses caused by the eccentricity of the thrust lines from the curved shape of the ring. This is confirmed by the thrust lines indicated in Figure 9, which although shown for the equilibrium model are almost identical to those from the conforming model.

The tensile stresses are mainly removed by the actions of self weight except for two zones: in the intrados under the concentrated load where a residual stress of some 0.5 N/mm^2 exists, and in the extrados at the left hand abutment where a residual stress of some 1.0 N/mm^2 exists.

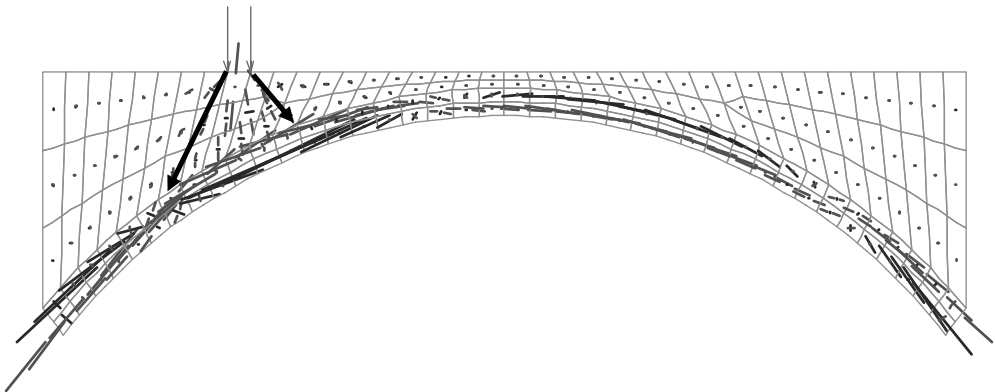

Figure 5: Principal stresses due to the concentrated load with the soft spandrel wall.

Figure 6 shows the deflected form of the arch ring for the case of the hard spandrel wall and only the concentrated load acts. The scales used for plotting are the same in Figures 4 and 6. An overall view of the load dispersion onto the arch is indicated by the plot of principal stresses shown in Figure 7, where the plotting scales are the same as those in Figure 5.

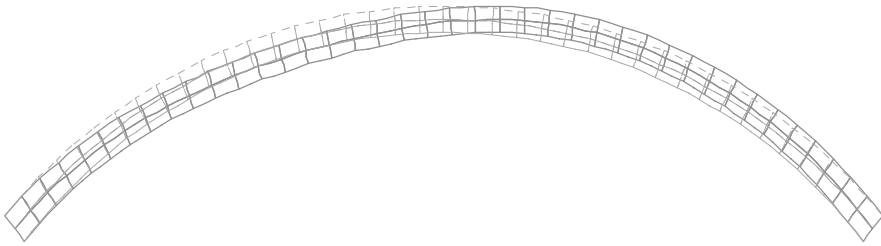

Figure 6: Deformed view of arch ring with hard spandrel wall.

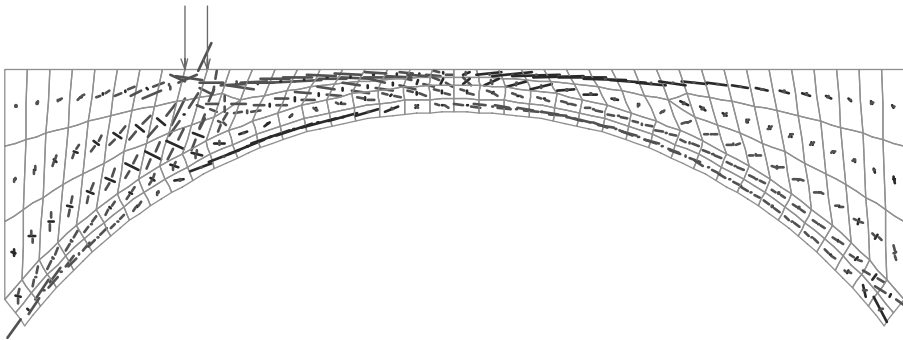

Figure 7: Principal stresses due to the concentrated load with the hard spandrel wall.

The pattern of stresses is now more akin to those in a curved beam where the arch ring acts as a stiffener to the beam formed by the spandrel wall. The thrust lines are presented in Figure 9, which indicates that these lines have been rotated so as to bring them closer to the abutments. The tensile stresses are now nearly removed by the actions of self weight as indicated in Figure 8. Horizontal tensile stresses of some 0.1 N/mm^2 remain in the top of the spandrel wall in the right hand end, and inclined tensions of some 0.05 N/mm^2 in the wall between the concentrated load and the arch extrados. The arch ring itself is free of tensile stress even at the abutments.

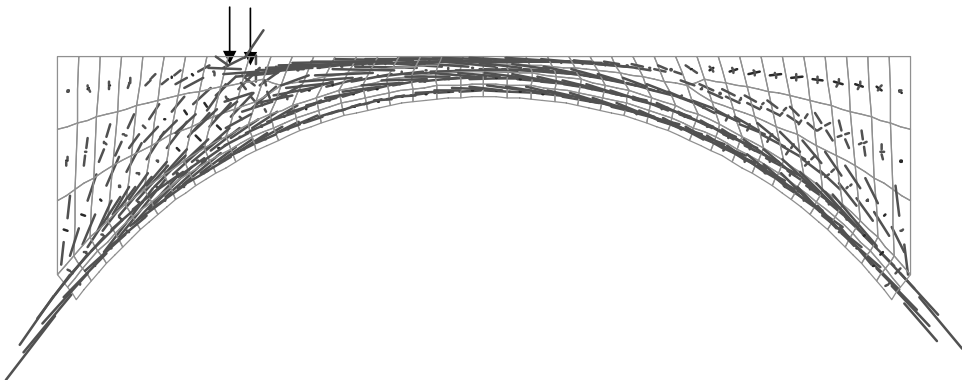

Figure 8: Principal stresses with hard spandrel wall including the self-weight of masonry

The stress values quoted are approximate and should be interpreted rather as orders of magnitude in the present context. Of particular interest in understanding the structural system is the interaction between the spandrel wall and the arch extrados. However the recovery of this

information from the conforming model is complicated by the additional need to transform element stresses to provide stress components normal and tangential to the extrados, and even then they will not generally be in equilibrium! Another method of recovering equilibrating tractions from nodal forces is possible, Ladeveze and Maunder (1996), but this involves further postprocessing.

3.2 Equilibrium models

A finite element model based on equilibrating elements is also shown in Figure 9, together with thrust lines for the concentrated load for the soft and hard spandrel walls. The solid and dashed lines correspond to the hard and soft walls respectively. This model consists of a much coarser mesh of hybrid elements whose polynomial degrees for representing stress fields or traction distributions on the sides of elements were varied up to degree 4. It should be noted that the nodes shown in Figure 9 are purely to describe the geometry of the elements, all interaction between elements is accounted for by appropriate side traction and displacement freedoms, as detailed in Almeida and Freitas (1991) and Maunder et al (1996).

The deflected forms and strain energies obtained from these models were almost identical to those from the conforming models, and hence they provide reassurance that the models are adequately simulating linear elastic type of behaviour. However the main results of interest concern the tractions acting on the arch extrados. These are shown due to the concentrated load by the piecewise linear lines in Figure 10. The horizontal axis in Figure 10 represents the developed surface of the extrados. Although degree 4 was used for the elements, for simplicity of presentation only the linear modes of normal traction and the constant modes of shear traction (or shear flow) are presented, these modes being of the minimum degree to establish element equilibrium.

These distributions indicate that the interaction between spandrel wall and arch ring is dominated by the shear flows, with the normal tractions being generally much smaller and in places tensile. This implies that friction alone would not provide a sufficient mechanism for shear transfer. Further analysis which includes self weight indicates that, although normal tractions become mainly compressive, friction may still be inadequate. Then some form of mechanical interlock between the voussoirs of the arch ring and the spandrel wall may be necessary to avoid delamination and to fully mobilise the shear flow required by this analysis. According to Mainstone (1998), the Romans introduced the idea of bonding an arch ring to its spandrel walls by the use of pentagonal voussoirs.

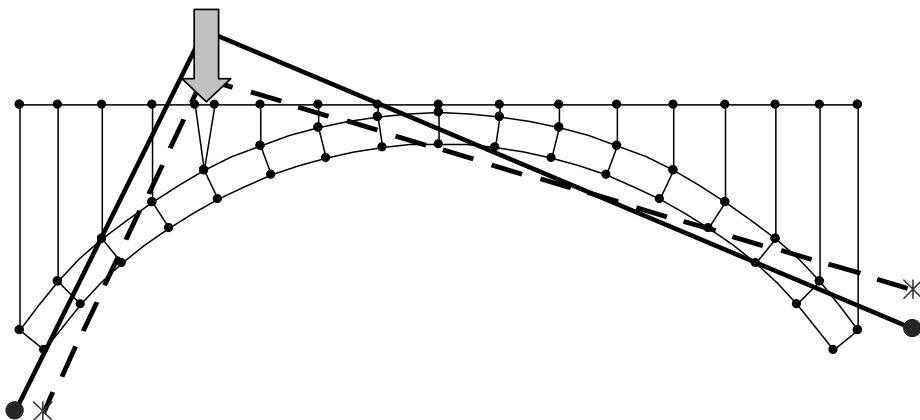

Figure 9: Mesh for an equilibrium finite element model, and thrust lines for a concentrated load

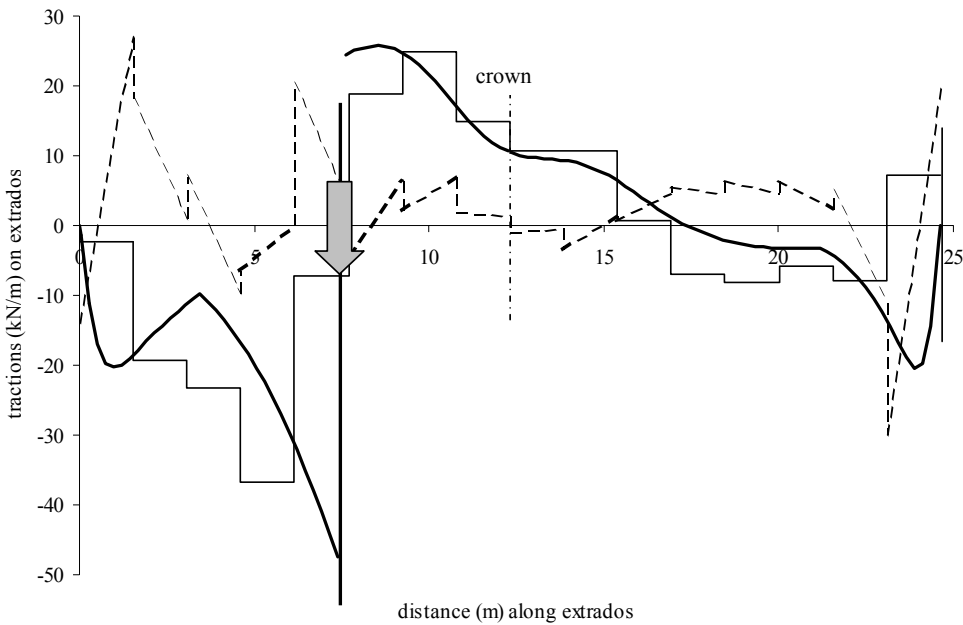

Figure 10: Interactions along the extrados due to a 100kN concentrated load: the fainter lines are from the equilibrium finite element model, the dashed line represents normal tractions (compression positive), the solid line represents shear traction; the heavier line represents shear traction from the curved beam model.

4 A CURVED BEAM AS A SIMPLIFIED MODEL

It has already been noted in Section 3.1 that with the hard spandrel wall the arch appears to act like a stiffened curved beam. Such a model was considered from the particular viewpoint of the shear flow interactions along the extrados. A curved tapered beam having an inverted T-section as a radial cross-section, as shown in Figure 11, was analysed to determine shear flows due to the forces in the solid thrust lines in Figure 9. Shear forces were obtained by resolving the thrusts in radial directions.

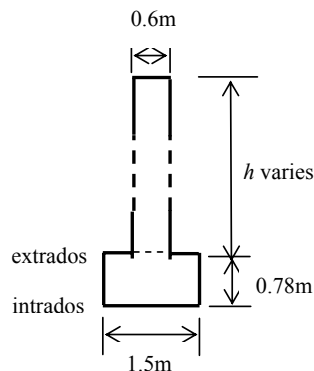

Figure 11: cross-section of spandrel wall and associated width of arch ring

The resulting distribution of shear flow is shown in Figure 10 by the bold solid curved line. The shear flow q kN/m was determined from Equation (1), which is in the standard form according to engineers' beam theory,

$$q = V \times \frac{Q}{I} \quad (1)$$

where V , Q , and I denote shear force, first moment of area of the arch ring section about the centroid of the section, and the second moment of area of the section about its centroid respectively.

Apart from zones adjacent to the abutments, the distribution is in good general agreement with the finite element distribution. The simplified beam model thus appears to capture the essential mode of interaction between the wall and the arch ring. The local peaks in shear flow near the abutments are consequences of the rapidly changing radial height h which starts from zero values at the abutments. As h increases from zero, Q increases at a faster rate than I for the first 0.6m along the extrados, but thereafter I increases at the faster rate.

5 GENERAL CONCLUSIONS

Analyses of a masonry arch with a spandrel wall have enabled comparisons to be made of the interactions between the wall and the arch ring due to concentrated live loads when the wall is soft, i.e. behaves as a soft fill, or when it is hard, i.e. behaves as a stiff wall. It is evident that the stiffness of the wall has a significant influence on the structural system for such loads, but this could be limited by delamination of the arch ring from the wall.

There can be no doubt that internal spandrel walls provide a load path for live loads which are stiffer and more direct than the arch ring. Analytical studies are limited by the limited knowledge of interaction with the surrounding environment. For example, the abutments of a bridge will present a closed wall to, typically, soil fill. The pressure exerted by the fill will have a considerable influence on the behaviour of the spandrel walls. It is therefore appropriate to seek a simple, conservative view of behaviour, and this might be achieved by using a thrust line analysis in which the live loads and dead loads are treated separately. The dead load would be supported within the arch, but the live load thrust might extend into the spandrels.

ACKNOWLEDGEMENTS

The second author acknowledges with thanks the financial support provided by a Leverhulme Trust Emeritus Fellowship during the preparation of this paper. The software used for producing Figures 3 to 8 was GSA version 8.1 as provided by Oasys Ltd.

REFERENCES

- Ladeveze, P. and Maunder, E.A.W. 1996. A general method for recovering equilibrating element tractions. *Computer Methods in Applied Mechanics and Engineering* 137(2), p. 111-151.
- Mainstone, R.J. 1998. *Developments in structural form*. 2nd ed., Oxford: Architectural Press.
- Maunder, E.A.W. Moitinho de Almeida, J.P. and Ramsay, A.C.A. 1996. A General Formulation of Equilibrium Macro-elements with Control of Spurious Kinematic Modes. *International Journal for Numerical Methods in Engineering* 39(18), p.3175-3194.
- Moitinho de Almeida, J.P. and Teixeira de Freitas, J.A. 1991. Alternative approach to the formulation of hybrid equilibrium finite elements. *Computers & Structures* 40, p. 1043-1047.
- Ruddock, E.C. 1974. Hollow spandrels in arch bridges: a historical study. *The Structural Engineer* 52(8), p. 281-293. (1974)